

# EXEGER™

Powerfoyle Indoor solar cells are ideal for developing solar-powered products that primarily use indoor light, such as remote controls, trackers, sensors, electronic shelf labels and more.

PRODUCT BRIEF - PRELIMINARY

POWERFOYLE INDOOR 1.5

Powerfoyle™

At Exeger, we have reinvented the dye-sensitized solar cell (DSC) with a new architecture that improves performance, provides greater flexibility and offers seamless integration possibilities.



High performance in indoor and outdoor light



Unaffected by partial shading



Surface textures



Flexible and durable



Environmentally-conscious



Design freedom

A [based on D68]

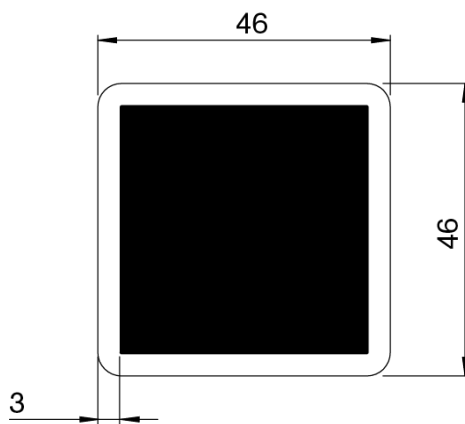

## NOTES

All data in this product brief is preliminary.

Unless otherwise stated, all data shown is for 25° C and is based on initial measurements directly after manufacturing. The light source used for measurements and data is YUJI D50 and the lux level is calibrated with DIG LUX 9500.

## TYPICAL CURRENT TO BATTERY AT 3.7 V

Size Absorber Area [cm <sup>2</sup> ]	50 Lux [μA]	100 Lux [μA]	200 Lux [μA]	500 Lux [μA]	1000 Lux [μA]
16.0 A [D68]	5.1	14.8	36.5	92.8	165.3

Values calculated from typical power density and overall boost converter efficiency. Typical performance variation is ±10% and is design dependent.

# SPECIFICATIONS

	Min	Max
Illuminance range [lux]		
Attuned range	50	500
Temperature range [°C]		
Ideal operating temperature	10	30
Maximum temperature range <sup>-</sup>	-20	45
Spectral response [nm]		
Attuned range	400	750
Ideal absorbance	400	650
Weight* [g] per cm <sup>2</sup>	0.12	0.17
Thickness <sup>+</sup> [mm]	1.3±0.2	
Typical dimensional tolerances [mm]	±0.3	
Typical bend radius <sup>#</sup>	Between 60 mm and 200 mm	

- <20% average performance reduction after 500h at 55°C /50%RH in darkness
- \* Depends on cell size
- + Depends on top layer and texture  
Excluding contact point and fpc.
- # Depends on design, especially aspect ratio

# TEMPERATURE DEPENDENCY

Lux	Temp Coeff Power [%/°C]	Temp Coeff Vmpp [%/°C]	Range, cell temperature [°C]
50	-0,7	-0,7	18-27
100	-0,6	-0,3	
200	-0,1	-0,3	
500	0,2	0,2	
1000	0,7	0,4	
50	-1,7	-1,6	25-35
100	-1,0	-0,9	
200	-0,8	-0,6	
500	-0,6	-0,4	
1000	0,1	0,2	

Measured on 40cm<sup>2</sup> cell.  
Temperature coefficient calculated versus cell performance at 25°C.

# POWER DENSITY [TYPICAL CELL PERFORMANCE]

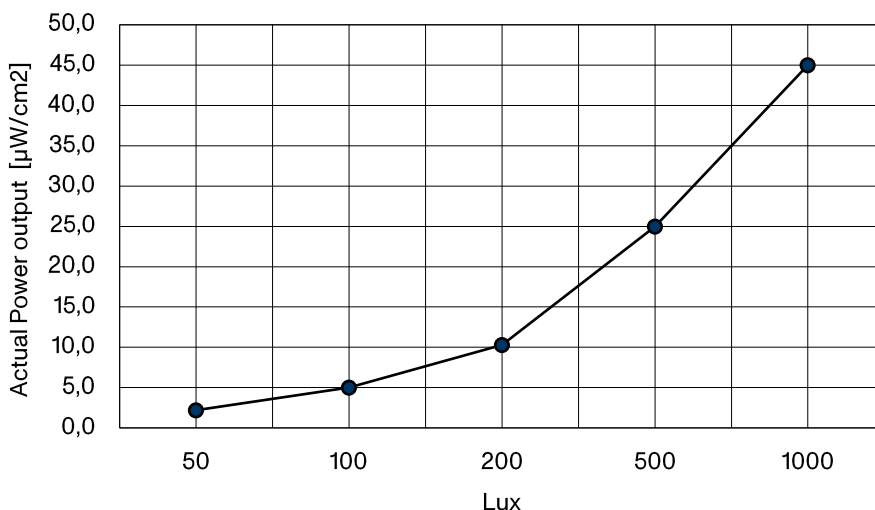

Same values as graph

Lux	Actual Power output [µW/cm <sup>2</sup> ]
50	2.2
100	5.0
200	10.3
500	25.0
1000	45.0

## MAXIMUM POWER POINT VOLTAGE [TYPICAL CELL PERFORMANCE]

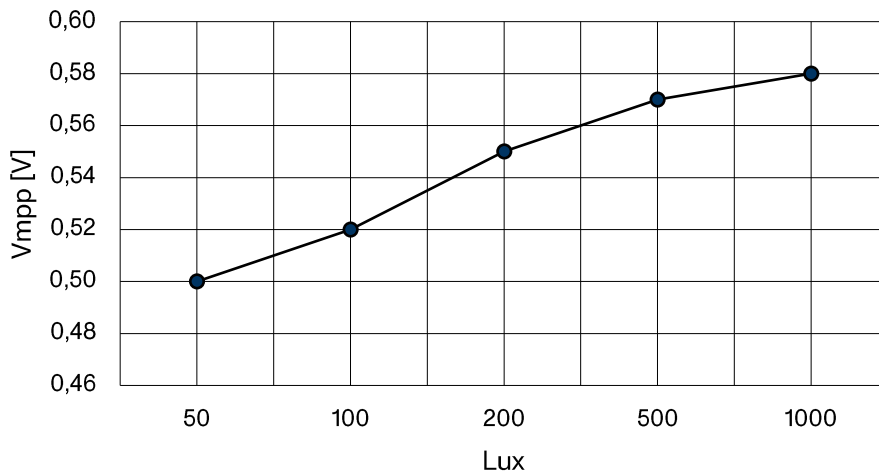

Same values as graph

Lux	Maximum power point voltage [V]
50	0.50
100	0.52
200	0.55
500	0.57
1000	0.58

## BOOST CONVERTER EFFICIENCY [TYPICAL PERFORMANCE]

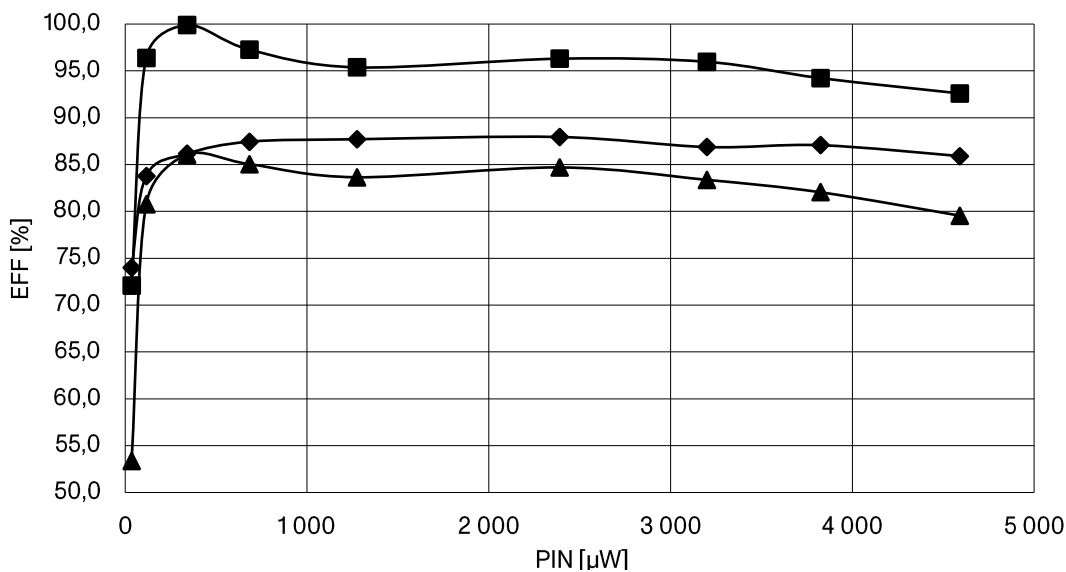

◆ DC/DC  
 ■ Tracking  
 ▲ Overall

Measured at room temperature using Exeger Boost101 reference design and output to 3.7V LiPo battery.

Same values as graph

Pin [ $\mu$ W]	DC/DC [%]	Tracking [%]	Overall [%]
35	74.0	72.1	53.3
116	83.8	96.4	80.8
340	86.2	99.9	86.1
684	87.4	97.3	85.0
1275	87.7	95.4	83.6
2389	87.9	96.3	84.7
3199	86.9	96.0	83.4
3824	87.1	94.2	82.0
4591	85.9	92.6	79.5