

EXEGER™

Powerfoyle Indoor solar cells are ideal for developing solar-powered products that primarily use indoor light, such as remote controls, trackers, sensors, electronic shelf labels and more.

PRODUCT BRIEF

POWERFOYLE INDOOR V3.0

At Exeger, we have reinvented the dye-Sensitized Solar Cell [DSC] with a new architecture that improves performance, provides greater flexibility and offers seamless integration possibilities.

Powerfoyle™



High performance in indoor light



Unaffected by partial shading



Surface textures



Flexible and durable



Environmentally conscious



Design freedom

A [based on PF110]

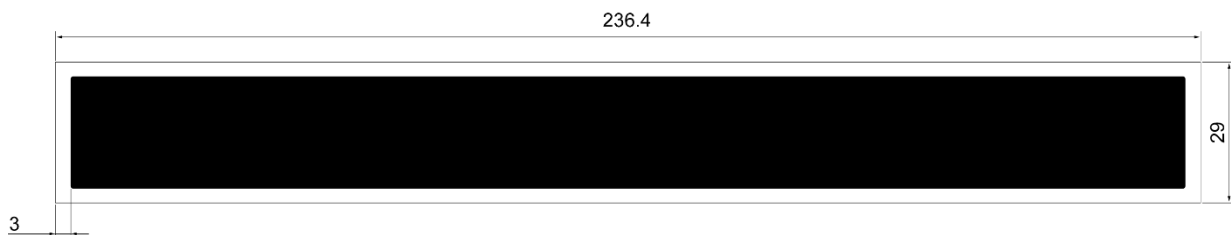

B [based on PF111]

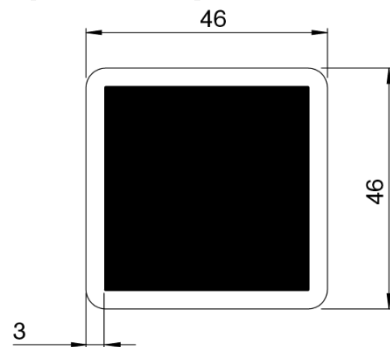

NOTES

All data in this product brief is preliminary.

Unless otherwise stated, all data shown is for 25° C and is based on measurements of PF110. For custom designs, performance per area is indicative.

The light source used for measurements and data is YUJI D50 and the lux level is calibrated with DIG LUX 9500.

TYPICAL CURRENT TO BATTERY AT 3.7 V

Size Absorber Area [cm ²]	100 Lux [μA]	200 Lux [μA]	500 Lux [μA]	1000 Lux [μA]
53.0 A [PF110]	73.5	150.7	360.7	650.4
16.0 B [PF111]	19.2	44.2	111.1	197.6

Values calculated from typical power density and overall boost converter efficiency.

SPECIFICATIONS

	Min	Max
Illuminance range [lux]		
Attuned range	50	500
Temperature range [°C]		
Ideal operating temperature	10	30
Maximum temperature range ⁻	-20	45
Spectral response [nm]		
Attuned range	400	750
Ideal absorbance	400	650
Weight* [g] per cm ²	0.12	0.17
Thickness ⁺ [mm]	1.3±0.2	
Typical dimensional tolerances [mm]	±0.3	
Typical bend radius [#]	Between 60 mm and 200 mm	

- <20% average performance reduction after 500h at 55°C /50%RH in darkness
- * Depends on cell size
- + Depends on top layer and texture
Excluding contact point and fpc.
- # Depends on design, especially aspect ratio

TEMPERATURE DEPENDENCY

Lux	Temp Coeff Power [%/°C]	Temp Coeff Vmpp [%/°C]	Range. cell temperature [°C]
100	-0.56	-0.37	18-27
200	-0.12	-0.23	
500	0.25	+0.06	
1000	0.72	+0.37	
100	-1.26	-0.65	25-35
200	-0.79	-0.39	
500	-0.34	-0.08	
1000	+0.00	+0.15	

Measured on 53.0 cm² cell.
Temperature coefficient calculated versus cell performance at 25°C.

POWER DENSITY AT MPP [TYPICAL CELL PERFORMANCE]

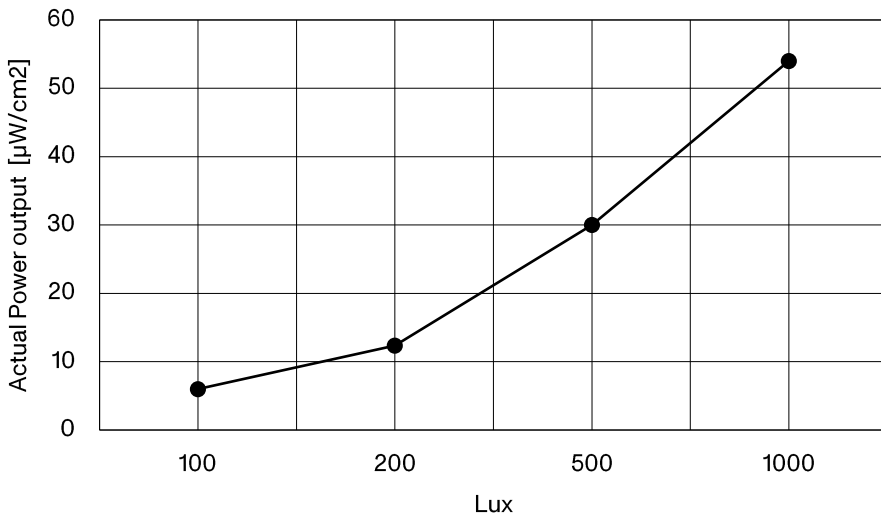

Same values as graph

Lux	Typical Power output [uW/cm ²]
100	6.0
200	12.4
500	30.0
1000	54.0

Minimum performance on delivery is 90% of typical performance.

MAXIMUM POWER POINT VOLTAGE [TYPICAL CELL PERFORMANCE]

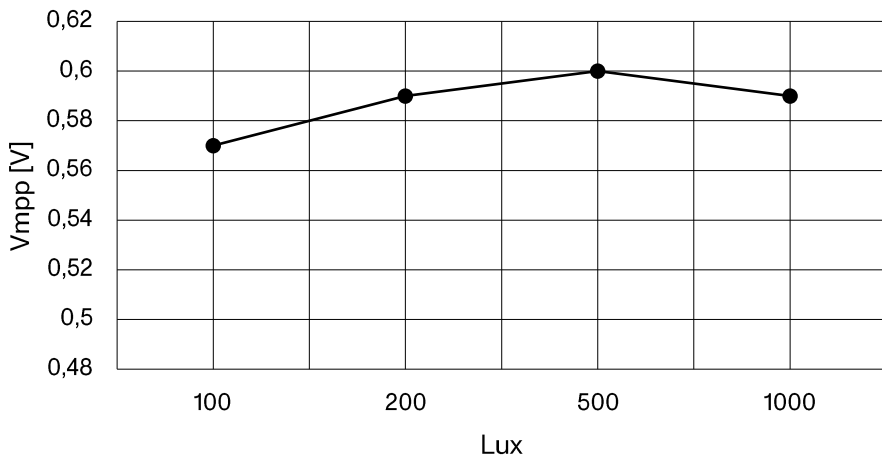

Same values as graph

Lux	Maximum Power Point Voltage [V]
100	0.57
200	0.59
500	0.60
1000	0.59

BOOST CONVERTER EFFICIENCY [TYPICAL PERFORMANCE]

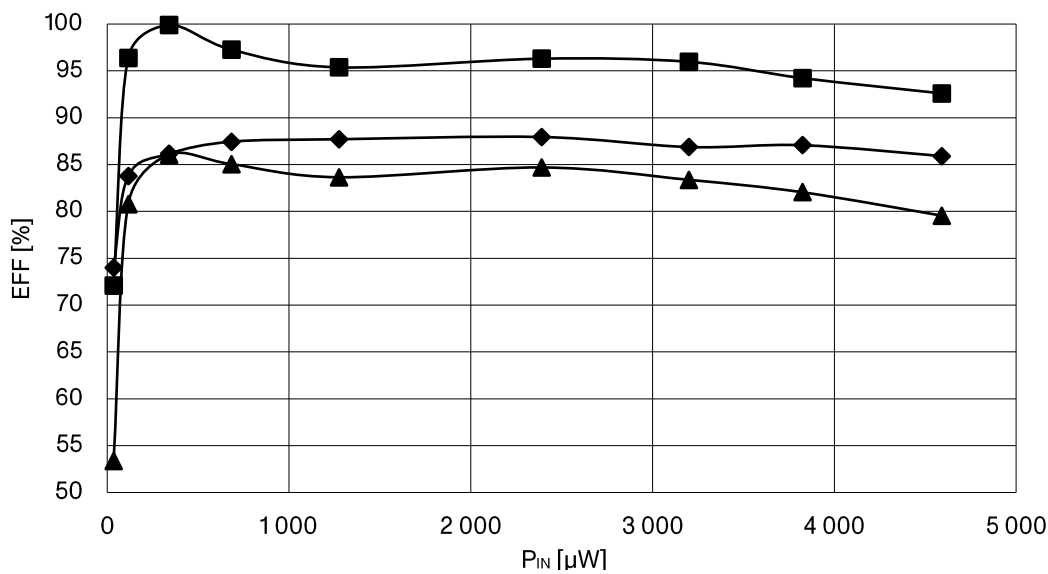

◆ DC/DC
 ■ Tracking
 ▲ Overall

Measured at room temperature using Exeger Boost101 reference design and output to 3.7V LiPo battery.

Same values as graph

P _{IN} [μW]	DC/DC [%]	Tracking [%]	Overall [%]
35	74.0	72.1	53.3
116	83.8	96.4	80.8
340	86.2	99.9	86.1
684	87.4	97.3	85.0
1275	87.7	95.4	83.6
2389	87.9	96.3	84.7
3199	86.9	96.0	83.4
3824	87.1	94.2	82.0
4591	85.9	92.6	79.5